

The Autec ASLP2007 is an on floor scissor lift with a capacity of 2000 kg which is specially designed to lift the smallest cars on the market. Thanks to a platform of only 1200mm this lift is the solution for workshops that maintain city cars on a regular basis. Equipped with galvanised platforms and high quality hydraulic components it is a reliable, secure and durable solution for your workshop.



- With a platform of only 1200mm you are able to lift even the smallest cars on the market wheel free;
- Standard lifting height of 1852 mm. The ASLP...H-models with special ground frame can lift up till 1987mm;
- Is durable through galvanisation of all parts expect the scissor;
- Minimum maintenance because of the hydraulic lifting system and the use high quality components;
- Extra safe through the usage of a double hydraulic system;
- Also secured against overloading and unequal descending of the platform;
- High handling speed, thereby reducing your variable cost;
- On floor installation provides flexibility in your workshop layout;
- Manual lowering device in case of power failure;
- Optimal working space around the lift because there are no columns;
- Lowering control valve;
- Also available with 230V motor.

Technical specifications	ASLP2007	ASLP2007H	ASLP2007/1ph
Lifting height (incl. pads)	1852 mm	1987 mm	1852 mm
Minimum height	104 mm	104 + 135 mm	104 mm
Lifting capacity	2000 kg		
With extended platforms	1500 kg		
Platform length	1200 mm		
Platform width	594 mm		
Lifting time (up / down)	45 seconds		
Working environment	Inside		
Lifting system	Electro- hydraulic		
Colour (scissors)	Blue (RAL 5015)		
Power supply	400v/3Ph/16A	400v/3Ph/16A	230v/1Ph/16A

Incl. 4 rubber pads
Inkl. 4 Gummiblöcke
Incl. 4 rubber blokken

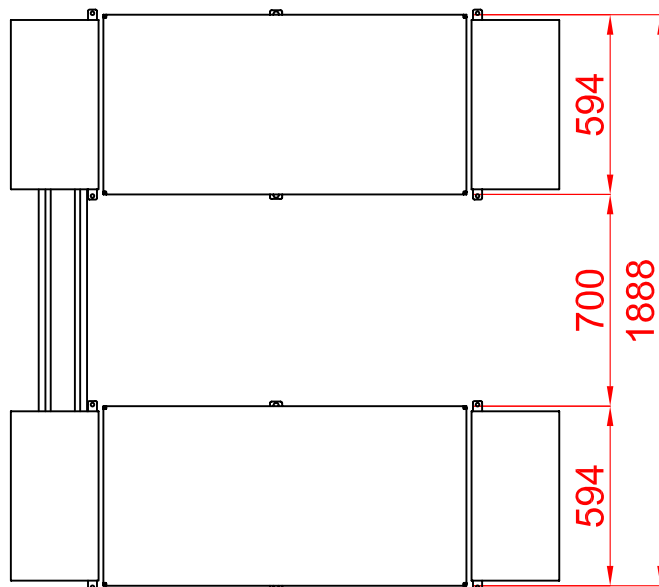
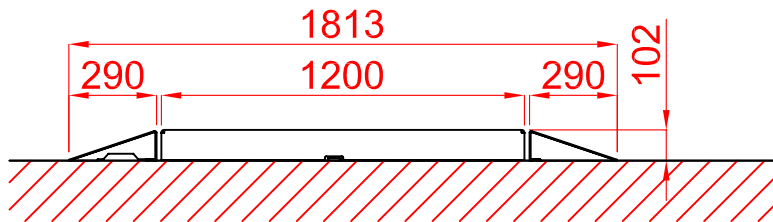
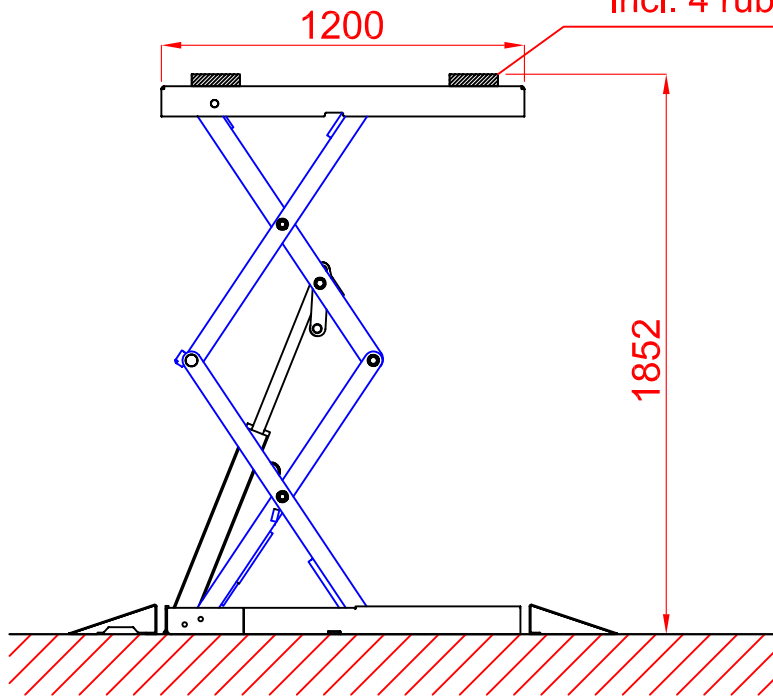

Incl. 4 rubber pads
Inkl. 4 Gummiblöcke
Incl. 4 rubber blokken

