

Scissor

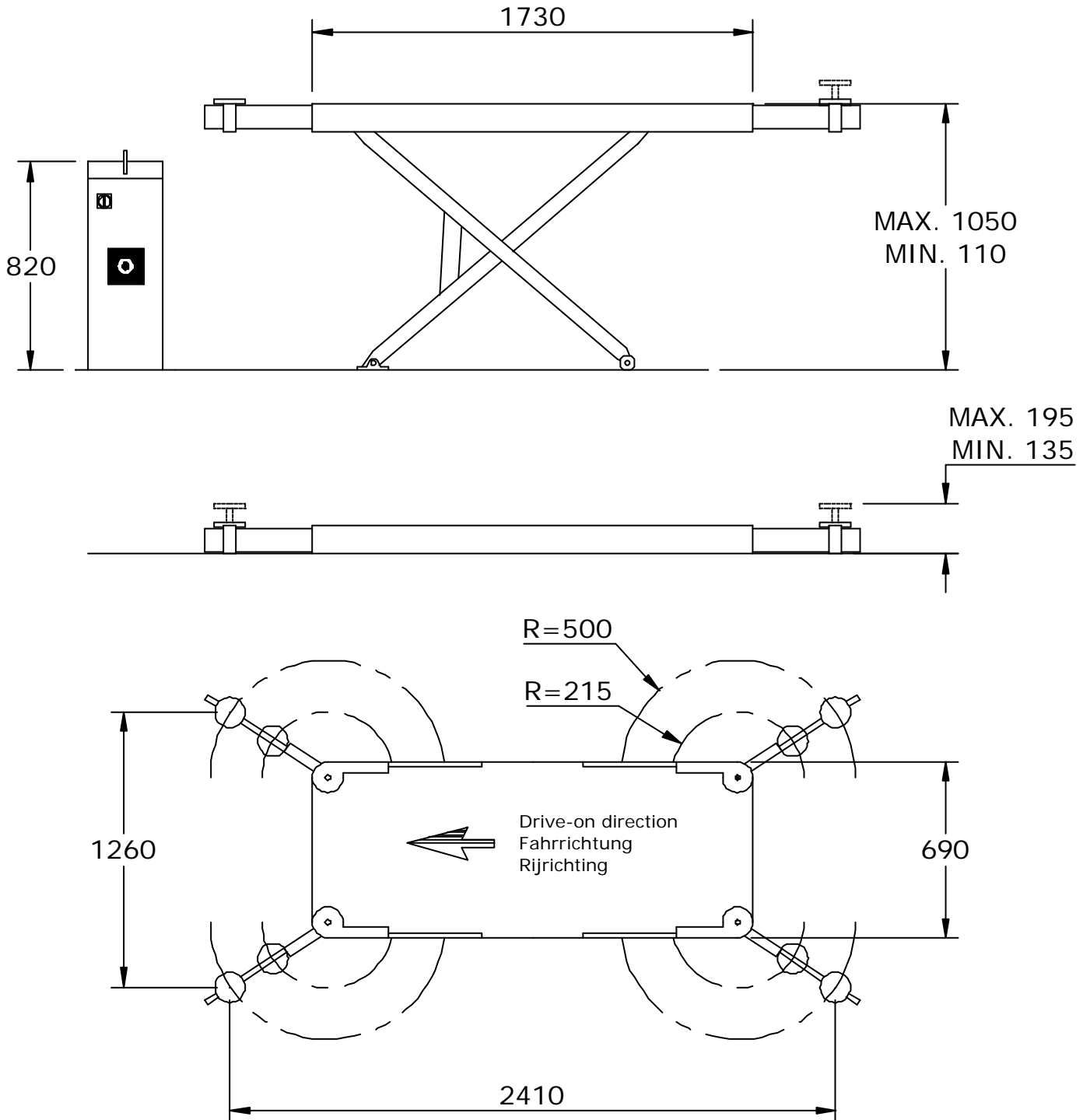

Scissor

Accessories / Zubehör / Accessoires:

--	--	--

Technical specifications / Technische Spezifikationen / Technische specificaties:

			AC2503C
Capacity	Tragfähigkeit	Hefvermogen	2.500 kg
Lifting time	Hebezeit	Heftijd	25 s
Descent time	Absenkzeit	Daaltijd	25 s
Noise level	Lärmpegel	Geluidsniveau	<70 dB (A) / 1 m
Working temp.	Arbeitstemp.	Werktemp.	-10 °C / + 40 °C
Working envir.	Arbeitsumgeb.	Werkomgeving	Indoor/Drinnen/Binnen
Motor power	Motorleistung	Motorvermogen	1,8 kW
Electr. Supply	Anschlußwert	Aansl. waarde	400 V / 50 Hz / 3 ph
Comp. air pressure	Preßluft	Perslucht	6-8 bar
Color	Farbe	Kleur	RAL 5015
CE number	CE Nummer	CE nummer	0877 150X0198 07 04
Notified body	Notified body	Notified body	Apave Normande

Packing/Verpackung/Verpakking:

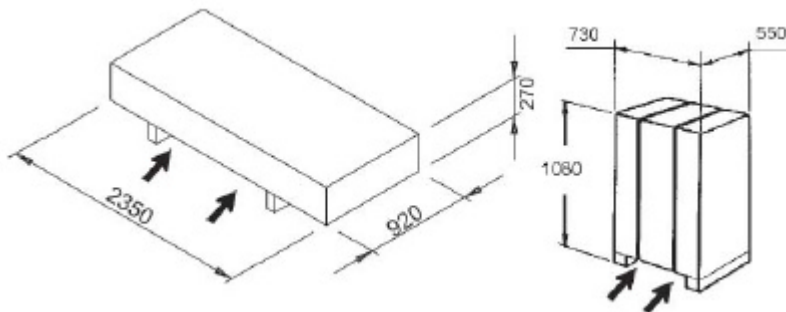

650 Kg

Container transport:

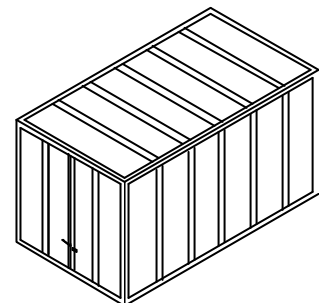

20 ft. = 24 pieces/Stück/stuks

