

ALH3225TC2

ALH3225TC3

ARMS CONSIST OF 2 PARTS
TRAGER 2 TEILE
ARMEN 2 DELIG

ARMS CONSIST OF 3 PARTS
TRAGER 3 TEILE
ARMEN 3 DELIG

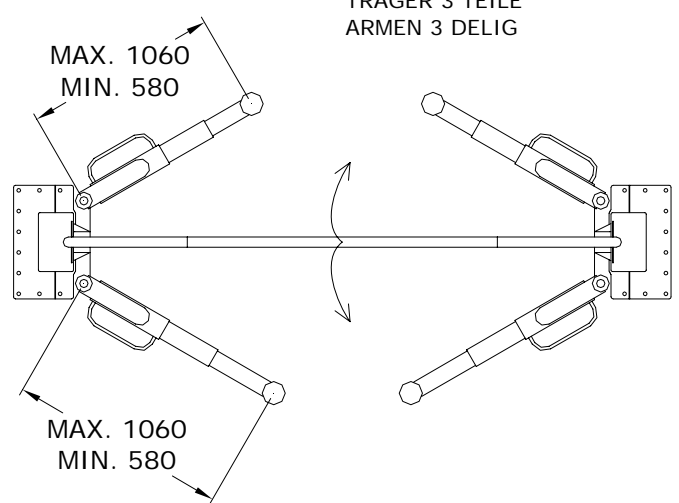
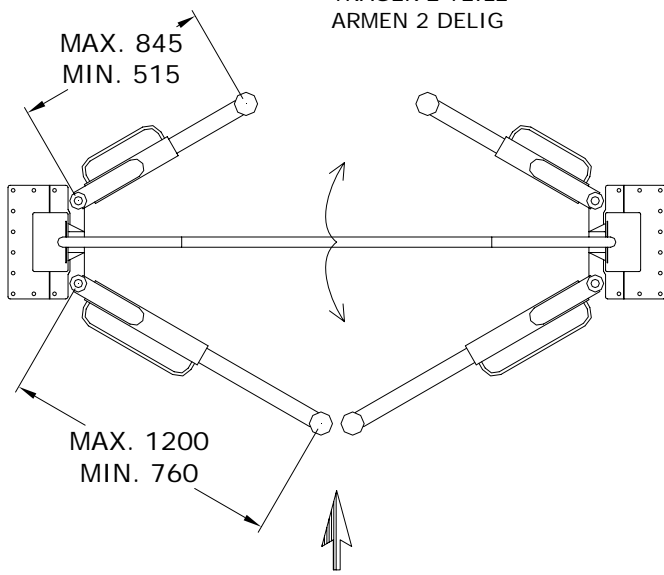



Accessories / Zubehör / Accessoires:

<p>Set (2) LED lighting Satz (2) LED Beleuchtung Set (2) LED verlichting</p>  <p>BA-A6LED/3225</p>		

Technical specifications / Technische Spezifikationen / Technische specificaties:

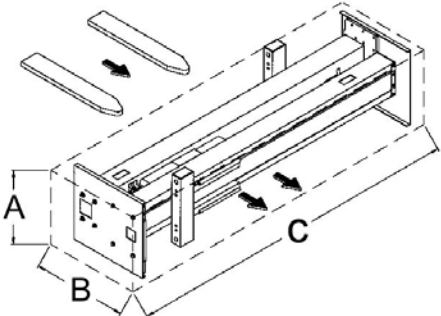
			ALH3225TC2 ALH3225TC3	ALH3225TC2/1ph
Capacity	Tragfähigkeit	Hefvermogen	3.200 kg	2.800 kg
Lifting time	Hebezeit	Heftijd	49 s	49 s
Descent time	Absenkzeit	Daaltijd	42 s	42 s
Noise level	Lärmpegel	Geluidsniveau	<74 dB (A) / 1 m	<74 dB (A) / 1 m
Working temp.	Arbeitstemp.	Werktemp.	-10 °C / +40 °C	-10 °C / +40 °C
Motor power	Motorleistung	Motorvermogen	2,6 kW	2,6 kW
Electr. Supply	Anschlußwert	Aansl. waarde	230/400V / 50Hz/ 3 Ph	230V / 50Hz/ 1 Ph
Color	Farbe	Kleur	RAL 5015-7038	RAL 5015-7038
Working envir.	Arbeitsumgeb.	Werkomgeving	Indoor/Dringen/Binnen	Indoor/Dringen/Binnen

<p>Packing/Verpackung/Verpakking:</p>  <p>A = 592 B = 755 C = 2550</p>	<p>Container transport:</p>  <p>20 ft. = 24 pieces/Stück/stuks</p>
--	--